

### Homework Set 5

1). One method of producing vacuum is to discharge water through a venturi tube, and connect the system to be evacuated with the throat of the venturi tube as shown in the below figure. How much water must discharge through the venturi tube to produce a vacuum of 20 inches mercury? The flow is incompressible and steady state, and you need to account for effects of gravity. Neglect frictional losses.

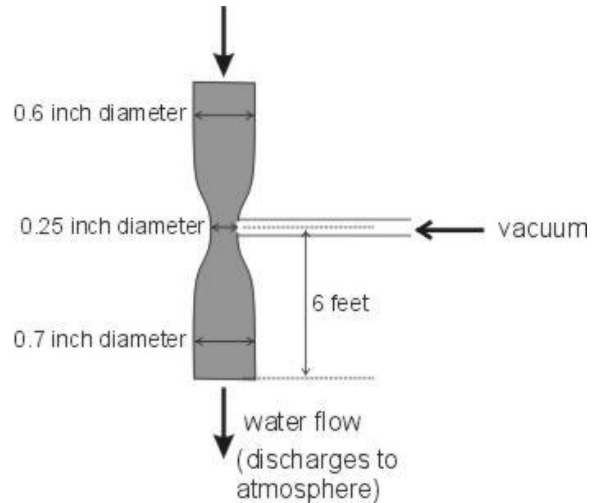

2). Water flows steadily up a pipe and enters an annular region between a pair of circular plates as shown in the below figure. It then moves out radially, leaving the gap between the plates as a free sheet of water.

- What is the flow rate of water through the pipe if the pressure at section A is 24.7 psi?
- What is the total force transmitted through the pipe wall at section A, if we neglect the weight of the pipe?

Notes: The flow is incompressible and steady state, and you need to account for effects of gravity *within the fluid*. Neglect frictional losses. Part b asks for the vertical force of the water on the pipe. Assume that the pipe and the annular region are made from a single, connected piece.

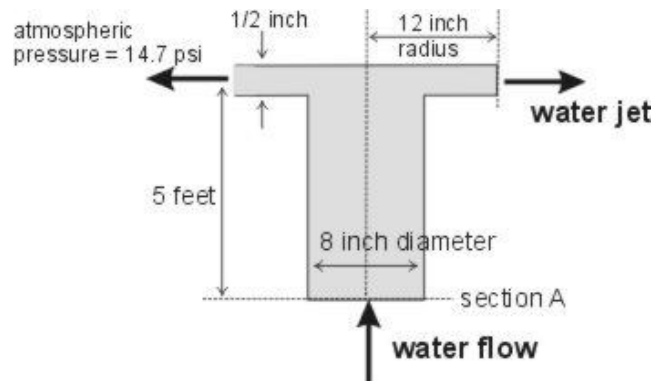

3). The stream function of an incompressible, two-dimensional flow is

$$\psi = x_1^2 + x_2^2$$

Does this flow have a velocity potential?

4). A potential vortex is located near an infinite plane at a distance  $h$  above the plane (see figure below). The pressure at infinity is  $p_o$  where the velocity is  $V_o$  parallel to the plane. The strength of the vortex is  $\Gamma$ . The fluid is incompressible and inviscid (ie. frictionless).

Find the total force, per unit width of the plane into the page, exerted on the plane if the pressure on the back side of the plane is  $p_o$ .

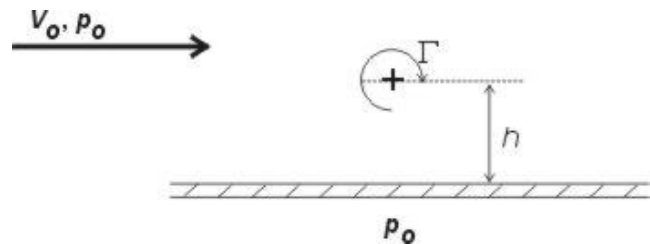

5). The following expression has been proposed for the velocity in turbulent pipe flow in the core region, outside the laminar sublayer:

$$\bar{v}_1^* = 2.5 \ln \left( \frac{3}{2} x_2^* \frac{1 + (r/R)}{1 + 2(r/R)^2} \right) + 5.5$$

a). Show that the above expression follows from the conservation of momentum law and the following expression for the eddy viscosity  $\varepsilon$

$$\frac{\varepsilon}{(\mu/\rho)} = C x_2^* \left( 1 + \frac{r}{R} \right) \left( 1 + 2 \frac{r^2}{R^2} \right)$$

if you assume that  $\frac{\varepsilon}{(\mu/\rho)} \gg 1$ . You may want to start the problem by working "backwards",

using the expression for  $\bar{v}_1^*$ .

b). Show that the above expression for  $\bar{v}_1^*$  satisfies the symmetry condition on velocity at  $r = 0$ .