

## 06. Kuhn: Normal Science



### 1. The Nature of Normal Science

- Paradigms gain status by being able to solve a particular set of problems or promise success at solving problems.
- Focus of attention on small range of problems allows detailed and in-depth investigations not otherwise possible.
- Thus: "Mopping up operations" are the key feature of normal science.

*Normal Science* =



# Three Types of Concerns of Normal Science

## Synopsis

- (1) Determination of Significant Fact
  - (2) Matching of Facts with Theory
  - (3) Articulation of Theory
    - (i) *Determination of fundamental constants*
    - (ii) *Determination of quantitative laws*
    - (iii) *Extending paradigm to new types of phenomena*
- Foci for *both* experimental and theoretical investigations.

# Three Types of Concerns of Normal Science

## (1) Determination of Significant Fact

Goal: To increase the accuracy and scope of those facts that are of initial concern for the paradigm.

Ex1: Stellar distances in Copernican astronomy.

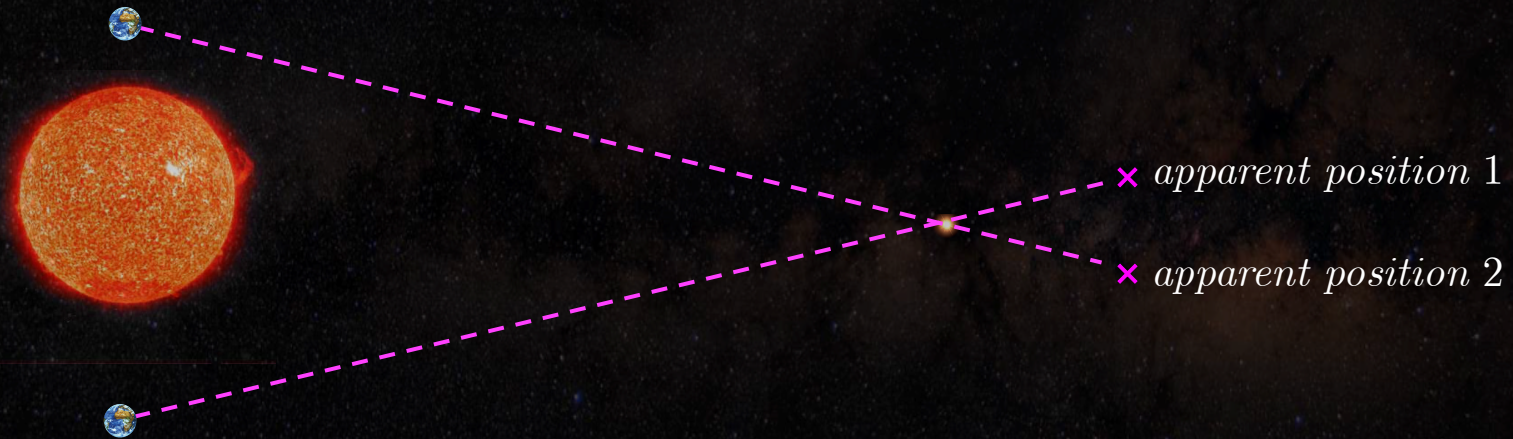

*If the Earth is in motion, why don't we observe stellar parallax?*

## Three Types of Concerns of Normal Science

### (1) Determination of Significant Fact

Goal: To increase the accuracy and scope of those facts that are of initial concern for the paradigm.

Ex1: Stellar distances in Copernican astronomy.

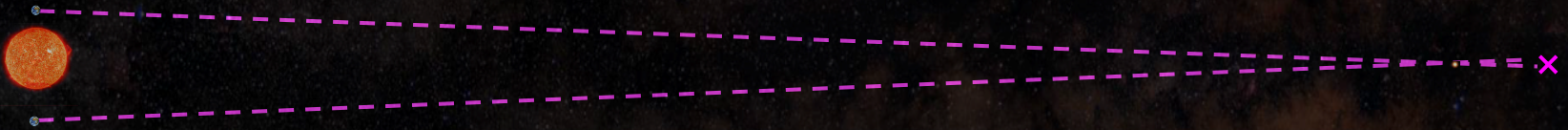

*Large stellar distances would explain lack of observed stellar parallax.*

## (2) Matching of Facts with Theory

Goal: To accommodate data under the current paradigm.

"... there are seldom many areas in which a scientific theory... can be directly compared with nature.... [E]ven in those areas where application is possible, it often demands theoretical and instrumental approximations that severely limit the agreement to be expected." (Kuhn, pg. 26.)

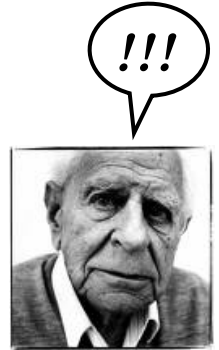

Ex. Classical tests of general relativity.

- (i) Bending of light near Sun.
- (ii) Perihelion shift of Mercury.
- (iii) Slowing of clocks in a gravitational field (gravitational red shift).



*1956 Pound-Rebka experiment at Jefferson Lab on Harvard campus.*

### (3a) Experimental Articulation of Theory

Goal: To experimentally embed theories within the explanatory framework of the current paradigm.

(i) *Determination of fundamental constants.*

Ex: Newtonian gravitational constant.

• *Newton's Law of Gravitation:*

$$F = \frac{Gm_1m_2}{r^2}$$

$m_1, m_2 =$  masses of objects  
 $r =$  distance between objects  
 $G =$  constant of proportionality

•  $G =$  Newtonian gravitational constant.

• How can we determine its value?

Cavendish experiment (1797-98).



Henry Cavendish  
(1731-1810)

Goal: Measure gravitational force between a large ball and a small ball in order to calculate the density of the Earth.

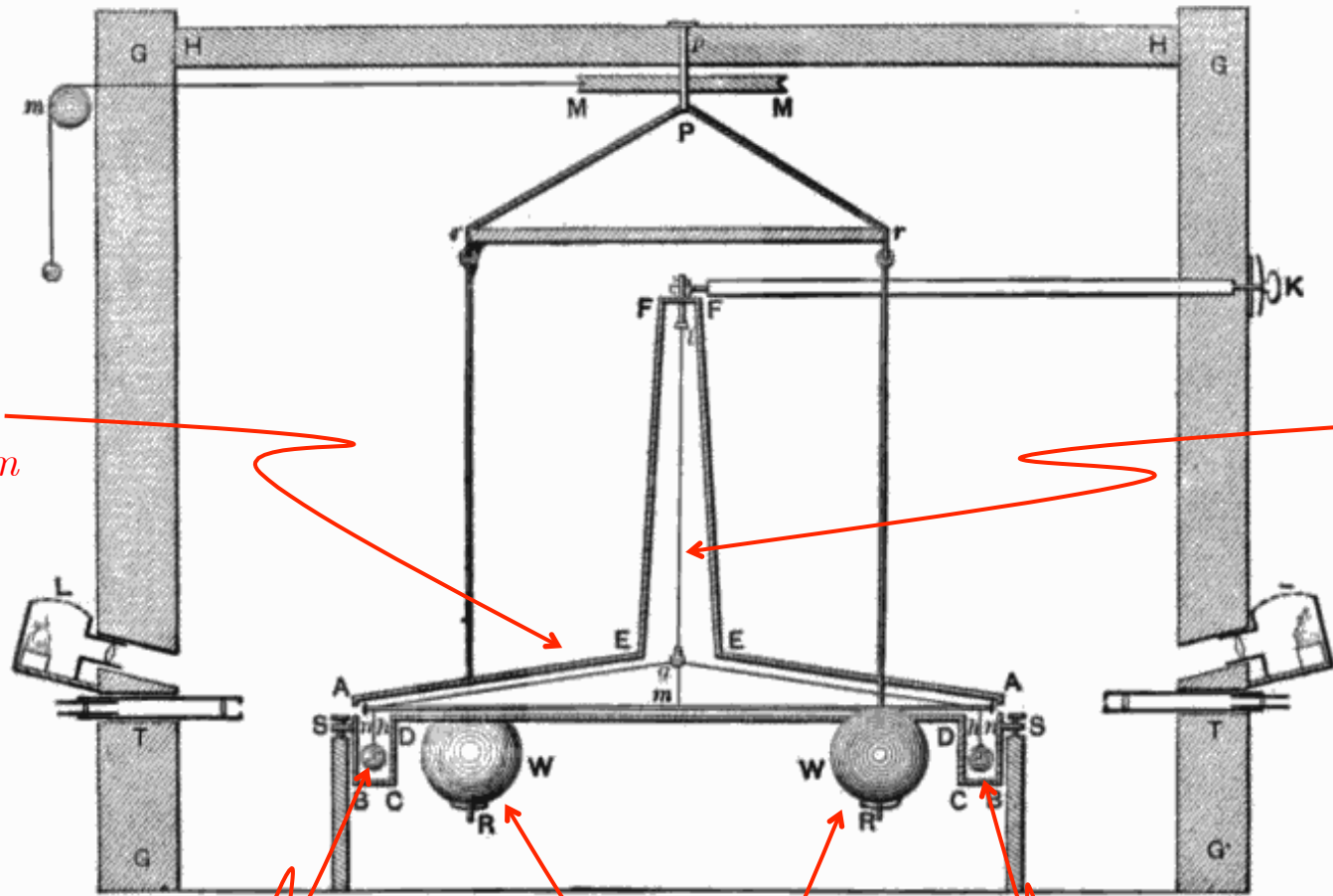

torsion  
balance arm

wire

small ball

large ball

small ball

Fig. 1



10314095

© Science Museum / Science & Society



(I) Gravitational force between large ball ( $m_1$ ) and small ball ( $m_2$ ):

$$F = \frac{G m_1 m_2}{R_{balls}^2} = \text{value obtained by Cavendish}$$

(II) Gravitational force between Earth ( $M_{Earth}$ ) and small ball ( $m_2$ ):

$$F = \frac{GM_{Earth} m_2}{R_{Earth}^2} = \text{weight of small ball} \quad R_{Earth} = \text{radius of Earth (known)}$$

• Ratio of (I) and (II):

$$\frac{\text{(value obtained by Cavendish)}}{\text{(weight of small ball)}} = \frac{R_{Earth}^2 m_1}{R_{balls}^2 M_{Earth}}$$

• Thus:

$$M_{Earth} = \frac{R_{Earth}^2 m_1}{R_{balls}^2} \times \frac{\text{(weight of small ball)}}{\text{(value obtained by Cavendish)}}$$

• So:

$$\text{density of Earth} = \frac{M_{Earth}}{\text{(volume of Earth)}}$$

- How do we get  $G$  from all this?
- Gravitational force between Earth and *any* object with mass  $m$ :

$$F = \frac{GM_{Earth} m}{R_{Earth}^2} = mg$$

*Newton's 2nd Law:*

$F = ma$ , where  $a = g =$  acceleration due to gravity on surface of Earth

- So:

$$G = \frac{gR_{Earth}^2}{M_{Earth}}$$

- Cavendish's original calculation of  $M_{Earth}$  entailed:

$$G = 6.754 \times 10^{-11} \text{ m}^3/\text{kg}\cdot\text{s}^2.$$

- Current estimate (Fixler *et. al* 2007):

$$G = 6.693 \times 10^{-11} \text{ m}^3/\text{kg}\cdot\text{s}^2.$$

*Lead (Pb) weight induces a relative phase shift between two samples of trapped laser-cooled cesium atoms.*

(Fixler, Foster, McGuirk, Kasevich 2007, *Science* **315**, pp. 74-77.)

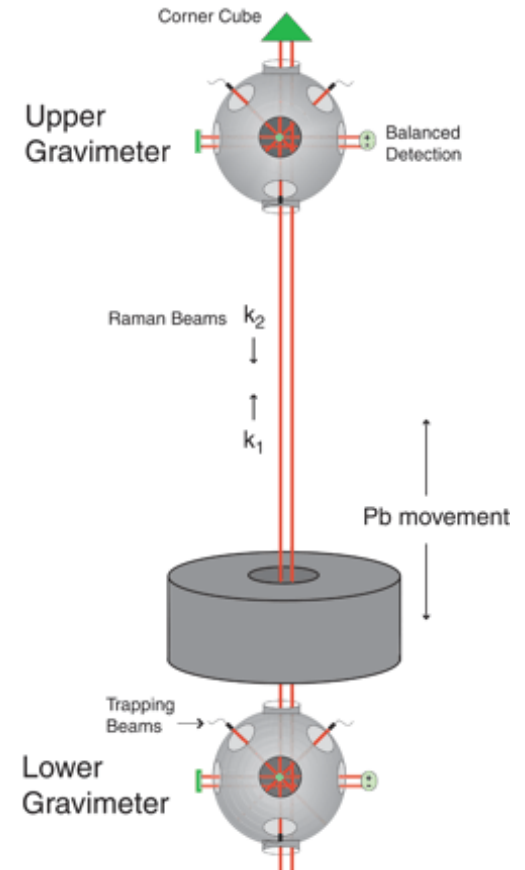

(ii) *Determination of quantitative laws.*

- Ex1: Boyles' Law for ideal gases (1662):
  - $PV = \text{constant}$  (at constant temperature).
  - Elastic fluid paradigm for air.



Robert Boyle  
(1627-1691)

- Ex2: Coulomb's Law of electrical attraction (1780's):
  - $F = \frac{kq_1q_2}{r^2}$
  - Elastic fluid paradigm for electricity.



Charles-Augustin  
de Coulomb  
(1736-1806)

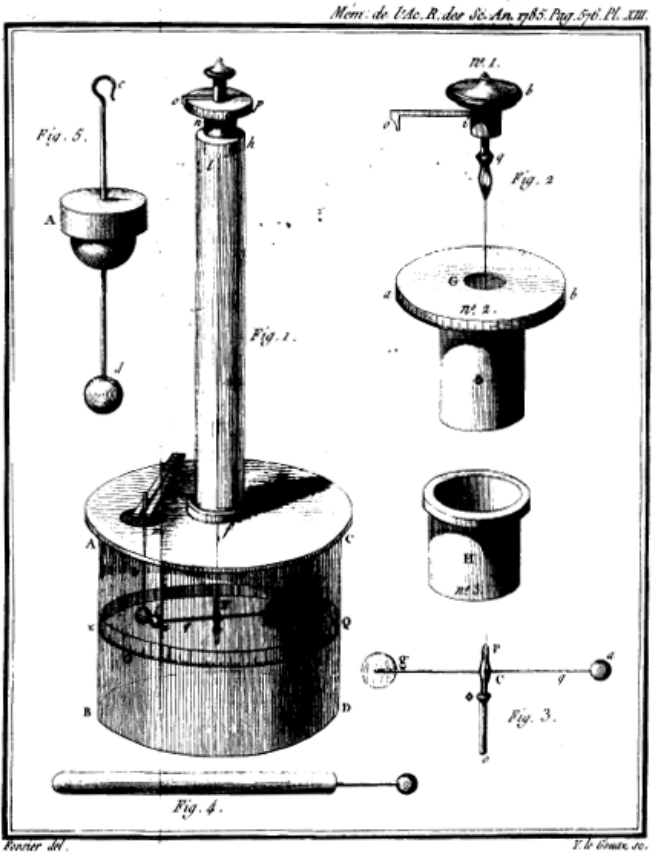

- Ex3: Joule's Law (1841):

- $Q = I^2 R t$ .

- Heat  $Q$  generated by current  $I$  flowing in a conductor with resistance  $R$  in time  $t$ .

- Kinetic paradigm for heat (heat as motion of particles).



*James Joule*  
(1818-1889)



(iii) *Extending paradigm to new types of phenomena.*

- Ex: Mechanical theories of the ether.
  - ether = 19th cent. medium for propagation of electromagnetic waves.
  - *Mechanical paradigm*: Treat ether like a system of interlocking gears.
  - Identify shear, stress, compression properties, *etc.*

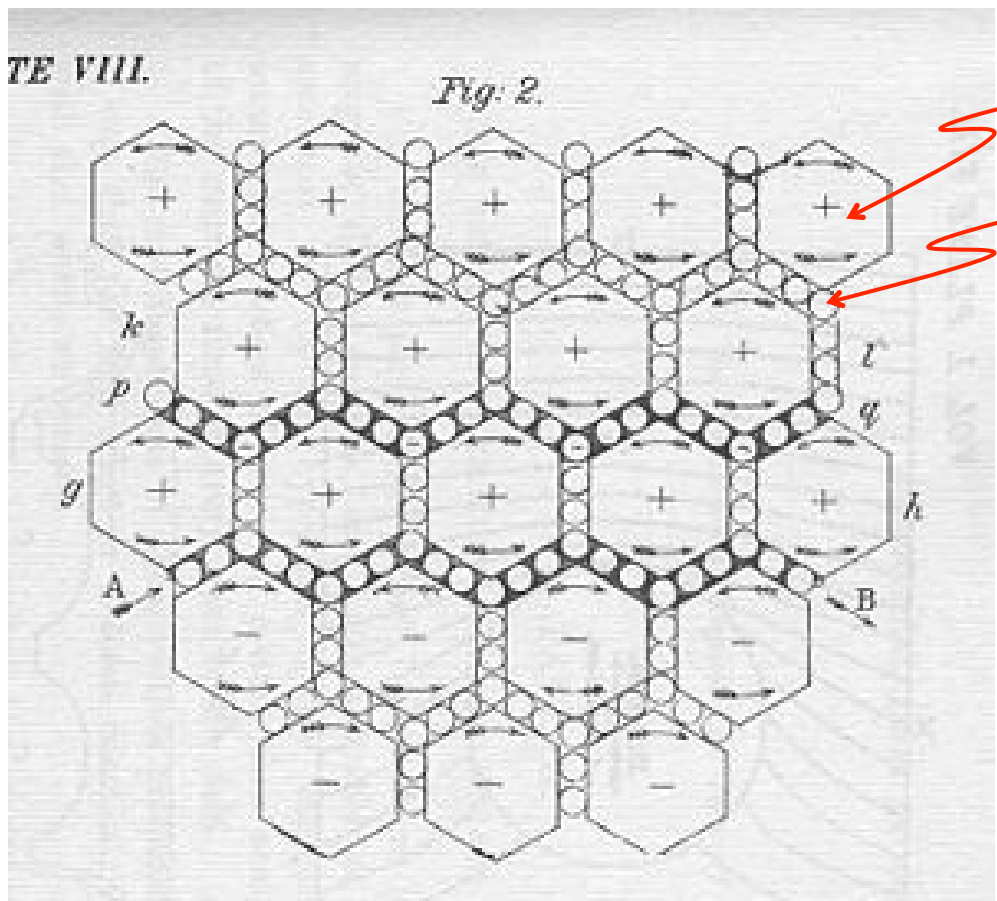

*motion of vortices = magnetism*

*motion of idle wheels = electricity*

Maxwell, J. C. (1861)  
"On Physical Lines of Force", *Phil Mag XXI*.



*James Clerk Maxwell*  
(1831-1879)

(3b) Theoretical Articulation of Theory: Mathematical reformulations of paradigm theory.

Ex: 18th-19th century reformulations of Newtonian mechanics.

- Newtonian mechanics (1687):

- $F = ma = md^2x/dt^2$

- Lagrangian mechanics (1788):

- Idea: Use generalized coordinate  $q$ ,  $dq/dt = \dot{q}$ . Good for systems experiencing constraining forces.

- $\frac{\partial L}{\partial q} = \frac{d}{dt} \frac{\partial L}{\partial \dot{q}}$ ,  $L = T - V$ .

- Hamiltonian mechanics (1833):

- Idea: Add generalized momentum  $p = \partial L / \partial \dot{q}$ . Simplifies equations.

- $\dot{p} = -\partial H / \partial q$ ,  $\dot{q} = \partial H / \partial p$ ,  $H = p\dot{q} + V$ .



Isaac Newton  
(1643-1727)

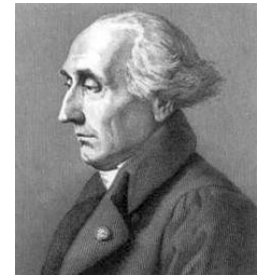

Joseph-Louis Lagrange  
(1736-1813)



William Rowan Hamilton  
(1805-1865)

## 2. Normal Science as Puzzle-Solving

- Aim of normal science:
  - Extend scope and precision of current paradigm = *puzzle-solving*.
  - *Not* to produce novel predictions!

*Puzzle* = task not yet solved, but possessing a solution.  
*Problem* = task not yet solved, possibly unsolvable.

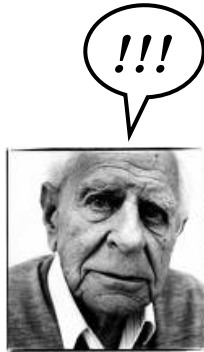

- A paradigm guides practitioners to *puzzles* (*i.e.*, issues that should be solvable within its framework).

"... achieving the anticipated in a new way." (Kuhn, pg. 36.)

Ex. Large Hadron Collider (LHC)

- dark matter
- extra dimensions
- Higgs boson
- supersymmetry

Uh-oh!



"Many of the magnets meant to whiz subatomic particles around the 17-mile underground Large Hadron Collider outside Geneva have mysteriously lost their ability to operate at high energies."

NYTimes 8/3/09.



- The individual engaged in normal science is *not*:
    - Testing long-established beliefs.
    - Opening up completely new territory.
    - Discovering order in nature.
- ← Puzzle-solving is *projecting* order *onto* nature.

- What's the reward?
  - The thrill of "... solving a puzzle that no one before has solved or solved so well" (Kuhn, pg. 38).



- Is there *progress* during normal science?
  - If scientists *only* take on problems that can be solved, then progress amounts to the *accumulation of solved puzzles*.

"One of the reasons why normal science seems to progress so rapidly is that its practitioners concentrate on problems that only their own lack of ingenuity should keep them from solving." (Kuhn, pg. 37.)



- Puzzles are problems with solutions that are constrained by *rules*.

#### 4 Types of Rules Governing Puzzle-Solving:

1. *Theoretical* = constraints imposed by the laws of a background theory.
2. *Instrumental* = constraints imposed by the types of acceptable instruments.
3. *Conceptual* = constraints imposed by metaphysical assumptions about the nature of the phenomena.
4. *Methodological* = constraints imposed by metaphysical assumptions about how best to investigate the nature of the phenomena.

- Which comes first, *paradigms* or *rules for puzzle-solving*?

## 2. The Priority of Paradigms

- A scientific community can *agree* on the identification of a shared paradigm, but *disagree* on how to interpret and use it (*i.e.*, on which rules to apply in solving the puzzles it presents).
  - *Relativistic paradigm* (1905, 1916): What does it say about the nature of space and time?
    - *Spacetime is a substance independent of physical objects?*
    - *Spacetime consists in the relations between physical objects?*
  - *Quantum paradigm* (1925): What does it say about the nature of matter?
    - *Properties of objects do not have values at all times?*
    - *Objects can be non-locally correlated with each other?*
    - *Whenever an interaction between objects occurs, the universe splits into as many copies as there are possible outcomes of the interaction.*

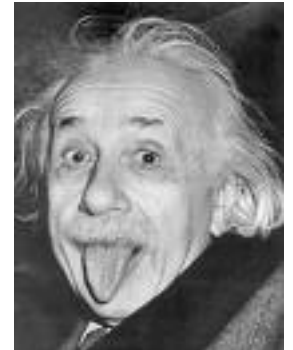

- How are rules within a paradigm identified?
- *Simplier question*: How are *chairs* identified?
- *chair* = 4 legs, back, seat, used for sitting, ...



- *Wiggenstein*: All chairs share a "family resemblance" in appropriate contexts of use.
- *Kuhn*: Same with identifying rules within a given paradigm.
  - No *explicit* instructions on how to use a paradigm.
  - Recall social role: practitioners are *indoctrinated* into a paradigm.



*Why many physicists aren't interested in interpreting their theories?*

So: Paradigms are *prior* to rules...

- The articulation of rules is *only* important during immature science and revolutionary science.
- During normal science,
  - Rules are not explicitly acknowledged.
  - Rules are learned by *doing*, not by saying.
  - Indoctrination into a paradigm (learning its rules) involves solving exemplar cases: simplified, standard problem sets.

Ex. Graduate study in physics = nit-picky puzzle-solving.

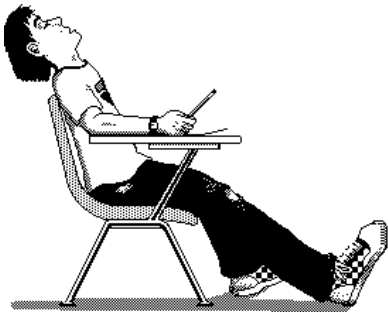

*Calculate the electric field for a conductor of this shape and given charge distribution.*